

**ELEVATION**

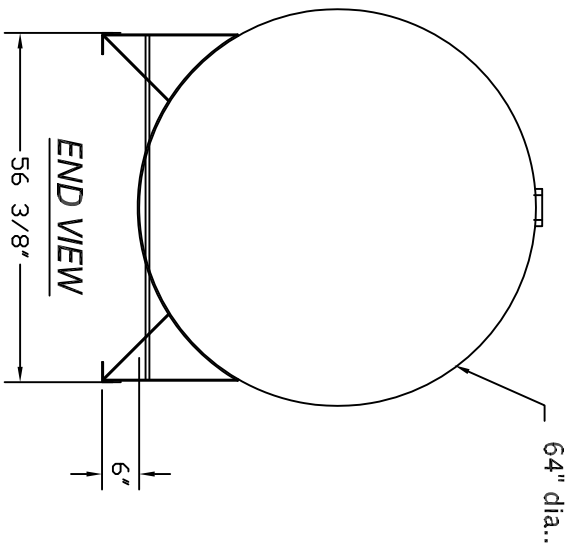

**END VIEW**

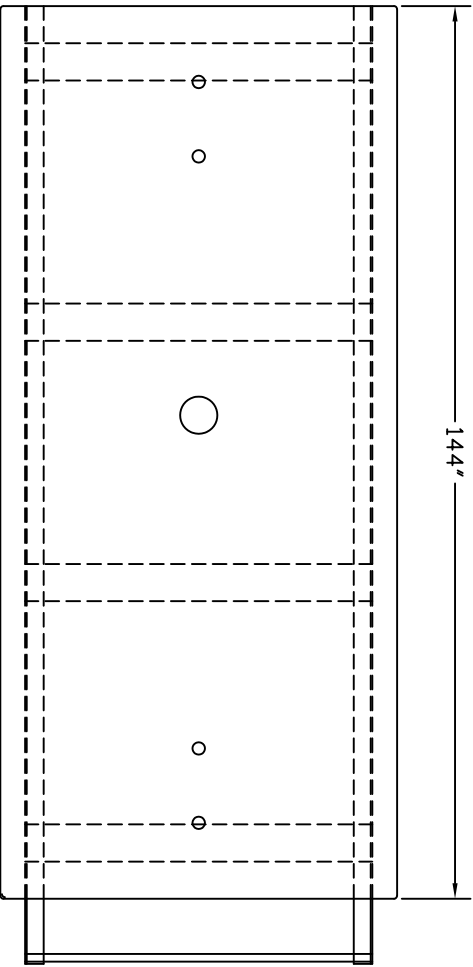

**TOP VIEW**

- GENERAL NOTES**
1. Tank is built per UL-142 specifications.
  2. Tank is made of A-36 carbon steel, 7 ga.
  3. Tank is pneumatically tested in the shop to 5 psig. Retesting on site by the customer is recommended.
  4. Tank is prime painted (gray).

INNER VENT CAP.	OUTER VENT CAP	DESCRIPTION	OVERALL SIZE	SHIP WT.
192,100	n/a	2000 GALLON SINGLE WALL TANK	64" x 70" x 146"	2360#



CUSTOMER NAME	<b>APPROVED</b> BY:	DATE:
---------------	---------------------	-------

DRAWN BY: GFS	DATE DRAWN: 4/9/08
DWG NUMBER: 22-02000	SCALE: 1:30
REV BY: GFS	DATE:
SHEET:	1