

ELEVATION

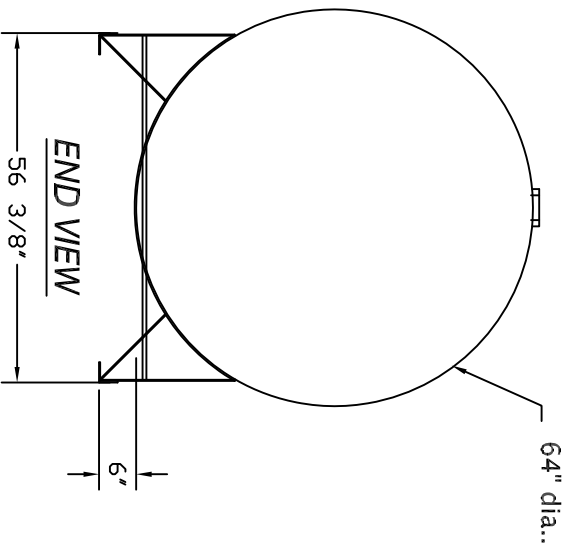

END VIEW

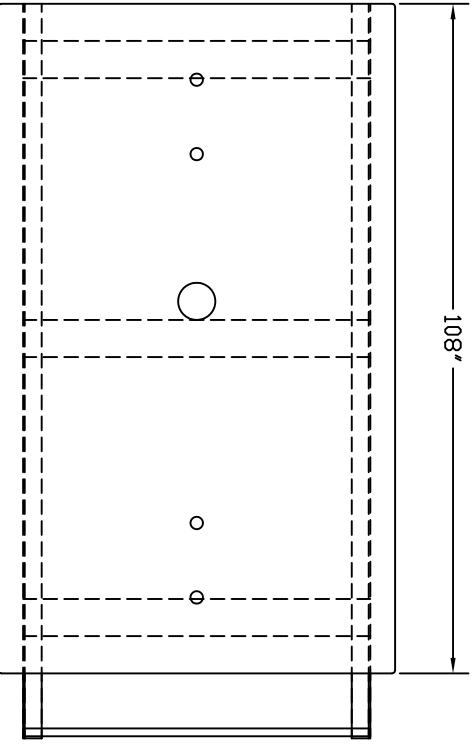

TOP VIEW

- GENERAL NOTES**
1. Tank is built per UL-142 specifications.
  2. Tank is made of A-36 carbon steel, 7 ga.
  3. Tank is pneumatically tested in the shop to 5 psig. Retesting on site by the customer is recommended.
  4. Tank is prime painted (gray).

INNER VENT CAP.	OUTER VENT CAP	DESCRIPTION	OVERALL SIZE	SHIP WT.
154,600	n/a	1500 GALLON SINGLE WALL TANK	64" x 70" x 112"	1975#

CUSTOMER NAME		<b>APPROVED</b> BY: _____		DATE: _____	
---------------	--	---------------------------	--	-------------	--



DRAWN BY: GFS	DATE DRAWN: 9/22/08
DWG NUMBER: 22-01500	SCALE: 1:30
REV: _____	REV BY: GFS
DATE: _____	SHEET: _____